



Digital Design with Synthesizable VHDL

Prof. Stephen A. Edwards
sedwards@cs.columbia.edu

Columbia University
Spring 2008

Why HDLs?

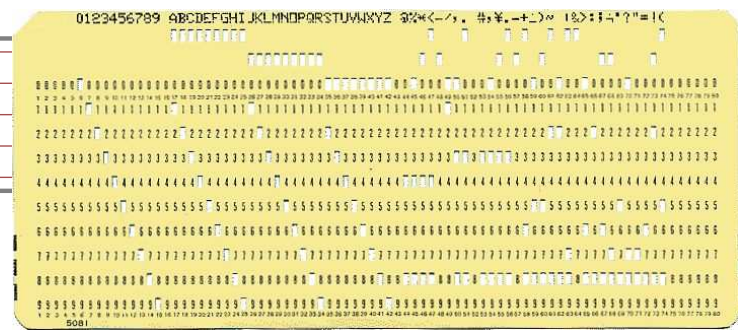

1970s: SPICE transistor-level netlists

An XOR built from four NAND gates

```
.MODEL P PMOS
.MODEL N NMOS

.SUBCKT NAND A B Y Vdd Vss
M1 Y A Vdd Vdd P
M2 Y B Vdd Vdd P
M3 Y A X Vss N
M4 X B Vss Vss N
.ENDS
```

```
X1 A B I1 Vdd 0 NAND
X2 A I1 I2 Vdd 0 NAND
X3 B I1 I3 Vdd 0 NAND
X4 I2 I3 Y Vdd 0 NAND
```

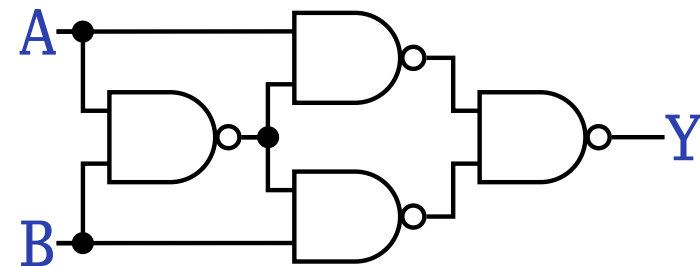
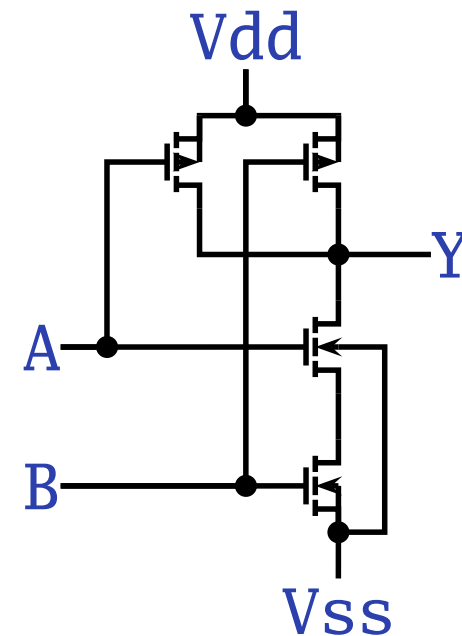

Why HDLs?

1980s: Graphical schematic capture programs

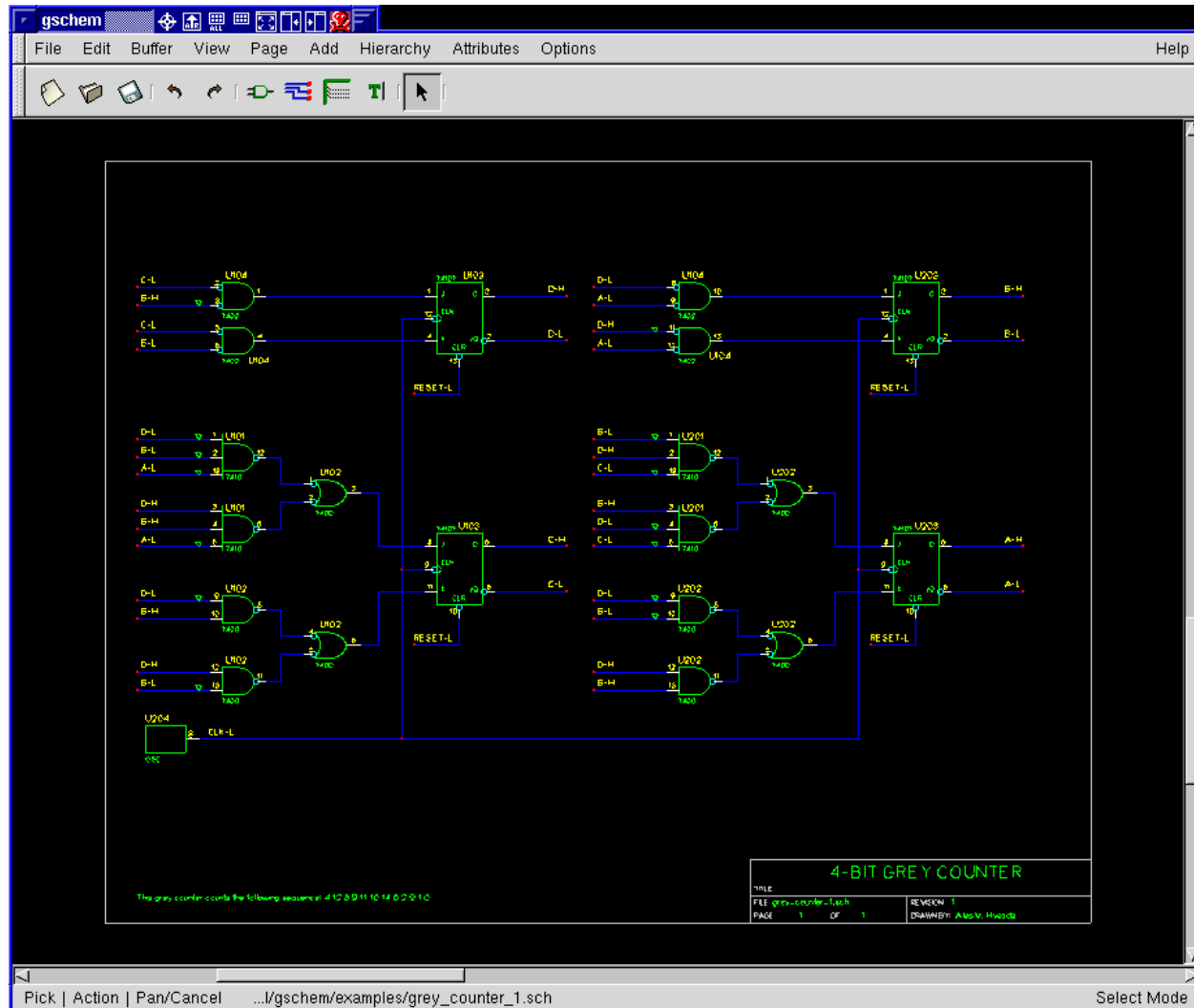

Why HDLs?

1990s: HDLs and Logic Synthesis

```
library ieee;
use ieee.std_logic_1164.all;
use ieee.numeric_std.all;

entity ALU is
port(   A:      in unsigned(1 downto 0);
        B:      in unsigned(1 downto 0);
        Sel:    in unsigned(1 downto 0);
        Res:    out unsigned(1 downto 0));
end ALU;
architecture behv of ALU is begin
  process (A,B,Sel) begin
    case Sel is
      when "00" => Res <= A + B;
      when "01" => Res <= A + (not B) + 1;
      when "10" => Res <= A and B;
      when "11" => Res <= A or B;
      when others => Res <= "XX";
    end case;
  end process;
end behv;
```

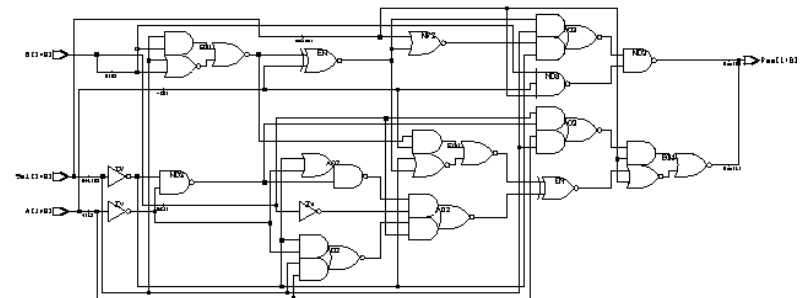

Two Separate but Equal Languages



Verilog and VHDL

Verilog: More succinct, less flexible, really messy

VHDL: Verbose, very (too?) flexible, fairly messy

Part of languages people actually use identical.

Every synthesis system supports both.

Basic Lexical Rules of VHDL

- Free-form: space only separates tokens.
- Case-insensitive: “VHDL,” “vHdL,” and “vhdl” are equivalent.
- Comments: from “--” to the end of the line.
- Identifiers: $[a-zA-Z](_?[a-zA-Z0-9])^*$

Examples: X X_or_Y ADDR addr

Illegal: 14M CLK__4 F00_

Literals in VHDL

- Decimal integers*: 1 42 153_1203
- Based integers*: 2#1_0010# 16#F001D#
- Characters: '0' '1' 'X'
- Strings: "101011" "XXXXXX"
- Bit string literals*: B"1001_0101" X"95"
mean "10010101"

*Underscores added for readability are ignored



Combinational Logic in a Dataflow Style

Bits

Logical	True	False
Binary	1	0
Voltage	1.65–3.3V	0–1.65V
Timing Diagram	—	—
VHDL	'1'	'0'

In VHDL, zeros and ones on wires are members of an enumerated type. *They are not Boolean.*

The std_logic_1164 package

```
package std_logic_1164 is
```

```
    type std_ulogic is
```

```
        ( 'U',  -- Uninitialized
          'X',  -- Forcing Unknown
          '0',  -- Forcing 0
          '1',  -- Forcing 1
          'Z',  -- High Impedance
          'W',  -- Weak Unknown
          'L',  -- Weak 0
          'H',  -- Weak 1
          '-'   -- Don't care
        );
```

```
    -- The std_logic type allows tri-state drivers (preferred)
```

```
    subtype std_logic is resolved std_ulogic;
```

```
    -- Lots more...
```

Boolean Operators

The basic ones in VHDL:

a	b	a and b	a or b	not a
'0'	'0'	'0'	'0'	'1'
'0'	'1'	'0'	'1'	'1'
'1'	'0'	'0'	'1'	'0'
'1'	'1'	'1'	'1'	'0'

a	b	a nand b	a nor b	a xor b
'0'	'0'	'1'	'1'	'0'
'0'	'1'	'1'	'0'	'1'
'1'	'0'	'1'	'0'	'1'
'1'	'1'	'0'	'0'	'0'

Rules of Boolean Algebra (1)

-- Precedence

not a or b and c = (not a) or (b and c)

-- Basic relationships

not not a = a

a and '1' = a

a and '0' = '0'

a or '1' = '1'

a or '0' = a

a and a = a

a and not a = '0'

a or a = a

a or not a = '1'

a nand b = not (a and b)

a nor b = not (a or b)

a xor '0' = a

a xor '1' = not a

a xor b = (not a and b) or (a and not b)

Rules of Boolean Algebra (2)

-- *Commutativity*

$a \text{ and } b = b \text{ and } a$

$a \text{ or } b = b \text{ or } a$

-- *Associativity*

$a \text{ and } (b \text{ and } c) = (a \text{ and } b) \text{ and } c$

$a \text{ or } (b \text{ or } c) = (a \text{ or } b) \text{ or } c$

-- *Distributivity*

$a \text{ and } (b \text{ or } c) = a \text{ and } b \text{ or } a \text{ and } c$

$a \text{ or } (b \text{ and } c) = (a \text{ or } b) \text{ and } (a \text{ or } c)$

-- *De Morgan's Law*

$\text{not } (a \text{ and } b) = \text{not } a \text{ or } \text{not } b$

$\text{not } (a \text{ or } b) = \text{not } a \text{ and } \text{not } b$

A Full Adder: Truth Table

a	b	c	carry	sum	carry <=
0	0	0	0	0	(not a and b and c) or
0	0	1	0	1	(a and not b and c) or
0	1	0	0	1	(a and b and not c) or
0	1	1	1	0	(a and b and c);
1	0	0	0	1	sum <=
1	0	1	1	0	(not a and not b and c) or
1	1	0	1	0	(not a and b and not c) or
1	1	1	1	1	(a and not b and not c) or
					(a and b and c);

Each row represents a minterm

Sum-of-products form: sum of each minterm in which output is true

Simplifying Using Boolean Rules

```
carry <= (not a and b and c) or (a and not b and c) or  
        (a and b and not c) or (a and b and c);
```

```
<= (a and b and not c) or (a and b and c) or  
   (not a and b and c) or (a and b and c) or  
   (a and not b and c) or (a and b and c);
```

```
<= (a and b) or (b and c) or (a and c);
```

```
sum <= (not a and not b and c) or (not a and b and not c) or  
       (a and not b and not c) or (a and b and c);
```

```
<= (not a) and ((not b and c) or (b and not c)) or  
   a and ((not b and not c) or (b and c));
```

```
<= a xor b xor c;
```

Structure of a VHDL Module

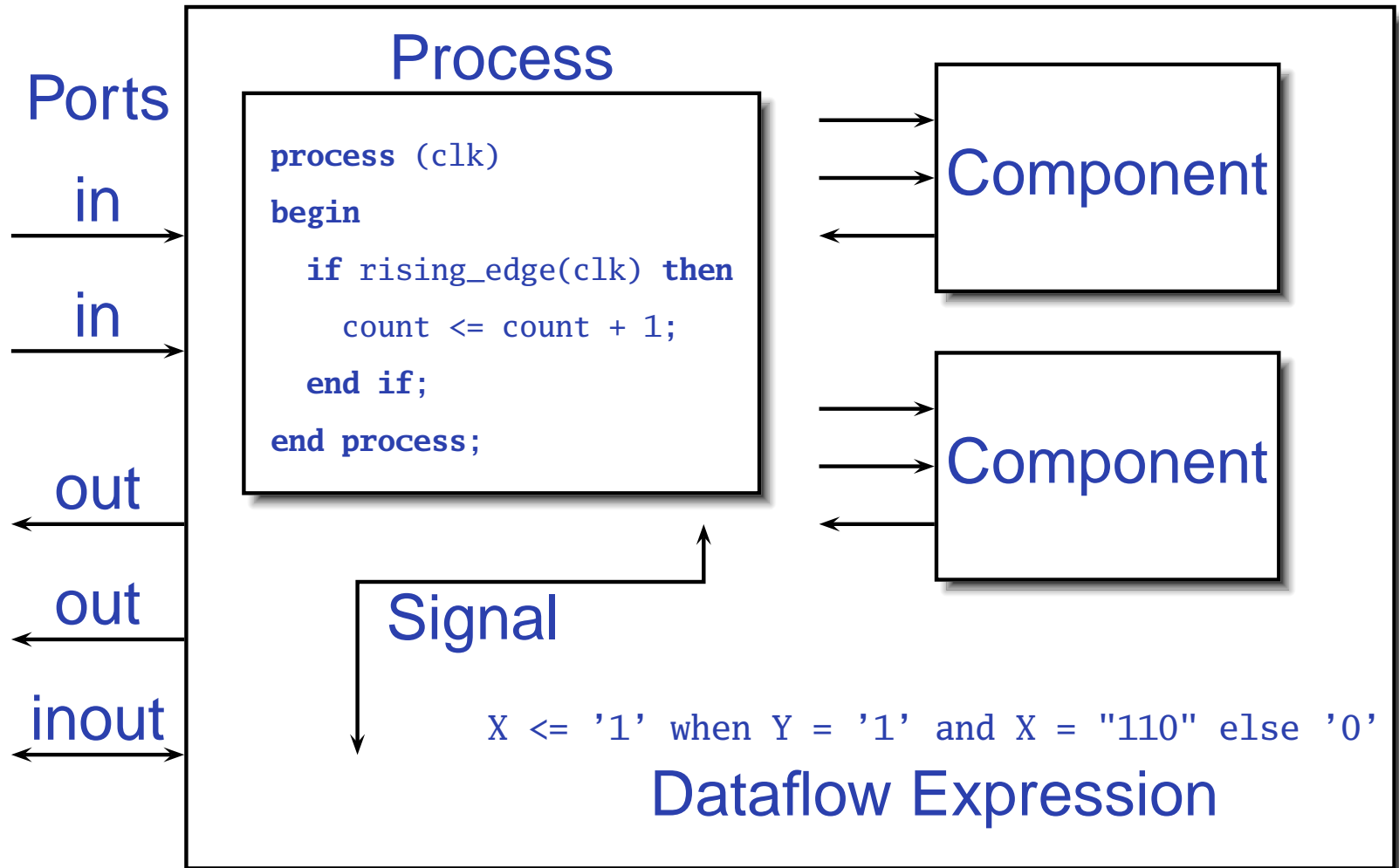

A Full Adder in VHDL



```
library ieee; -- always needed
use ieee.std_logic_1164.all; -- std_logic, et al.
```

```
entity full_adder is -- the interface
  port(a, b, c      : in  std_logic;
        sum, carry : out std_logic);
end full_adder;
```

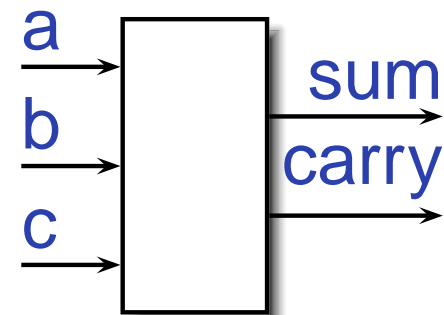

```
architecture imp of full_adder is -- the implementation
begin
  sum    <= (a xor b) xor c;    -- combinational logic
  carry <= (a and b) or (a and c) or (b and c);
end imp;
```

...After Logic Synthesis

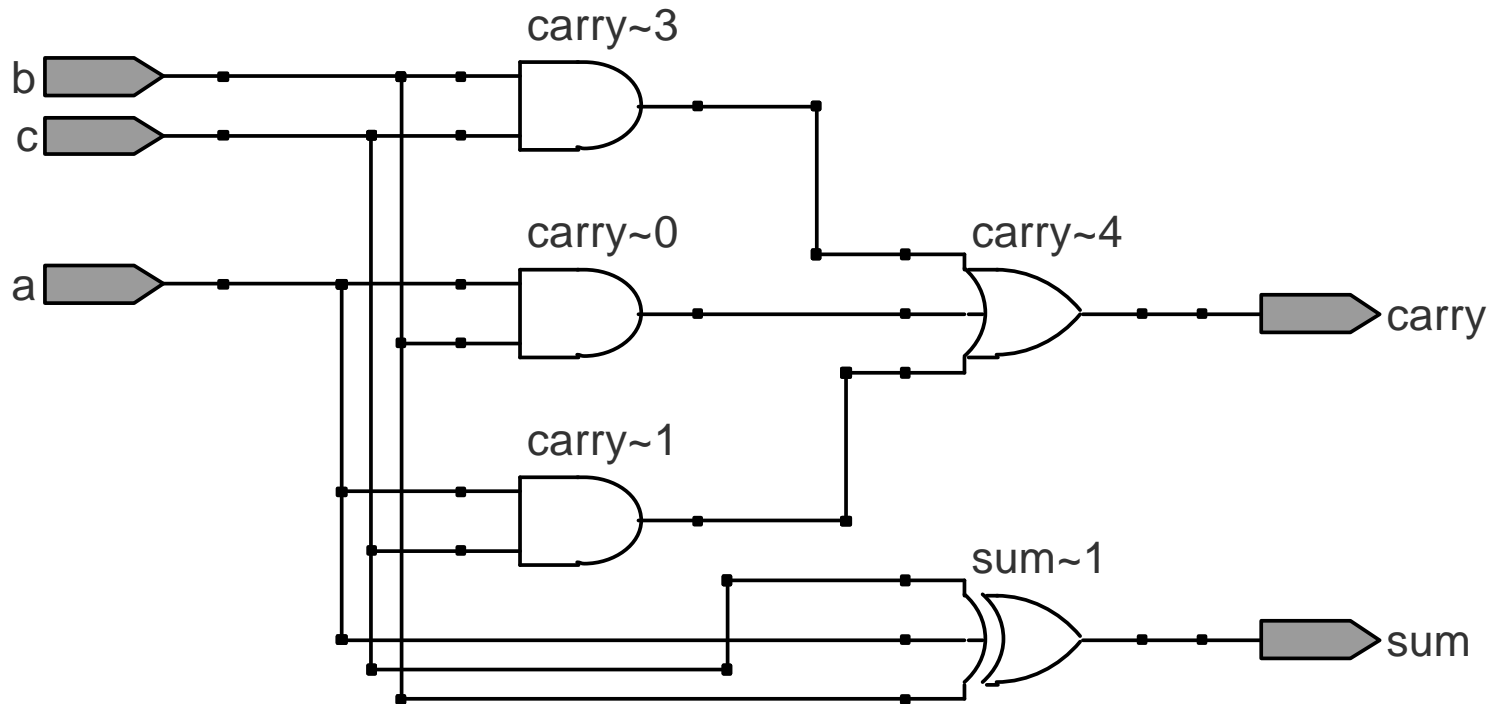

Vectors of Bits

Three standard synthesizable bit vector types:

Type	Library	Logic	Arith.	Neg.
std_logic_vector	ieee_std_1164	✓		
unsigned	numeric_std	✓	✓	
signed	numeric_std	✓	✓	✓

```
library ieee;
use ieee.std_logic_1164.all;
use ieee.numeric_std.all;

entity vectors is
  port(vect : in std_logic_vector(1 downto 0);
       unsi : in unsigned(7 downto 0);
       sign : out unsigned(15 downto 0));
end entity;
```

Endianness

The perpetual battle: Is “0” most or least significant?

Little Endian 3 2 1 0 unsigned(3 **downto** 0)

Big Endian 0 1 2 3 unsigned(0 **to** 3)

Arguments on both sides will continue forever.

I suggest using Little Endian for vectors.

Binary and Hexadecimal in VHDL

Decimal	Binary	Hex
0	"0"	x"0"
1	"1"	x"1"
2	"10"	x"2"
3	"11"	x"3"
4	"100"	x"4"
5	"101"	x"5"
6	"110"	x"6"
7	"111"	x"7"
8	"1000"	x"8"
9	"1001"	x"9"
10	"1010"	x"A"
11	"1011"	x"B"
12	"1100"	x"C"
13	"1101"	x"D"
14	"1110"	x"E"
15	"1111"	x"F"
16	"10000"	x"10"
17	"10001"	x"11"
18	"10010"	x"12"
19	"10011"	x"13"

Vector types are arrays of `std_logic`

Literals are therefore strings of 0's and 1's

```
-- from std_logic_1164  
type std_logic_vector is  
    array (natural range <>) of std_logic;
```

```
--- from numeric_std  
type unsigned is  
    array (natural range <>) of std_logic;
```

```
type signed is  
    array (natural range <>) of std_logic;
```

Two's Complement

Decimal	Binary	Hex
-8	"1000"	x"8"
-7	"1001"	x"9"
-6	"1010"	x"A"
-5	"1011"	x"B"
-4	"1100"	x"C"
-3	"1101"	x"D"
-2	"1110"	x"E"
-1	"1111"	x"F"
0	"0000"	x"0"
1	"0001"	x"1"
2	"0010"	x"2"
3	"0011"	x"3"
4	"0100"	x"4"
5	"0101"	x"5"
6	"0110"	x"6"
7	"0111"	x"7"

How do you represent negative numbers?

Two's complement produces simpler logic than sign bit alone.

Idea: Add constant 2^n to negative numbers. Simply discard overflow after addition or subtraction.

An n -bit number represents -2^{n-1} to $2^{n-1} - 1$.

The signed type in `numeric_std` uses this

A Hex-to-seven-segment Decoder

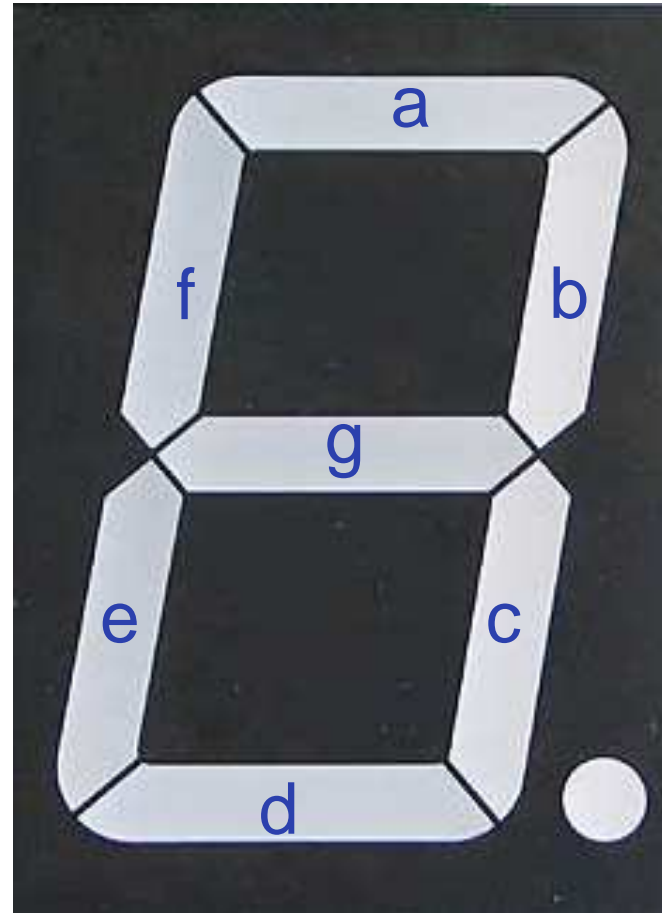

VHDL: Hex-to-7-segment Decoder

```
library ieee;
use ieee.std_logic_1164.all;
use ieee.numeric_std.all; -- Provides the unsigned type
entity hex7seg is
    port ( input  : in  unsigned(3 downto 0); -- A number
          output : out std_logic_vector(6 downto 0)); -- Just bits
end hex7seg;
architecture combinational of hex7seg is
begin
    with input select output <=
        "0111111" when x"0", "0000110" when x"1", -- Bad style
        "1011011" when x"2", "1001111" when x"3", -- one case
        "1100110" when x"4", "1101101" when x"5", -- per line
        "1111101" when x"6", "0000111" when x"7", -- preferred
        "1111111" when x"8", "1101111" when x"9",
        "1110111" when x"A", "1111100" when x"B",
        "0111001" when x"C", "1011110" when x"D",
        "1111001" when x"E", "1110001" when x"F",
        "XXXXXXX" when others;
end combinational;
```

Four-to-one mux: when .. else

```
library ieee;
use ieee.std_logic_1164.all;
use ieee.numeric_std.all;

entity multiplexer_4_1 is
    port(in0, in1, in2, in3 : in  unsigned(15 downto 0);
          s                   : in  unsigned(1 downto 0);
          z                   : out unsigned(15 downto 0));
end multiplexer_4_1;

architecture comb of multiplexer_4_1 is
begin
    z <= in0 when s = "00" else
        in1 when s = "01" else
        in2 when s = "10" else
        in3 when s = "11" else
        (others => 'X'); -- Shorthand for "all X's"
end comb;
```

Four-to-one mux: with...select

```
library ieee;
use ieee.std_logic_1164.all;
use ieee.numeric_std.all;

entity multiplexer_4_1 is
    port(in0, in1, in2, in3 : in  unsigned(15 downto 0);
          s0, s1             : in  std_logic;
          z                  : out unsigned(15 downto 0));
end multiplexer_4_1;

architecture comb of multiplexer_4_1 is
    signal sels : unsigned(1 downto 0);
begin
    sels <= s1 & s0; -- "&" is vector concatenation
    with sels select -- would not resolve type if "s1 & s0" here
        z <= in0      when "00",
            in1       when "01",
            in2       when "10",
            in3       when "11",
            (others => 'X') when others;
```

Three-to-eight Decoder

```
library ieee;
use ieee.std_logic_1164.all;
use ieee.numeric_std.all;
entity dec1_8 is
port (
    sel : in  unsigned(2 downto 0);
    res : out unsigned(7 downto 0));
end dec1_8;

architecture comb of dec1_8 is
begin
    res <= "00000001" when sel = "000" else
           "00000010" when sel = "001" else
           "00000100" when sel = "010" else
           "00001000" when sel = "011" else
           "00010000" when sel = "100" else
           "00100000" when sel = "101" else
           "01000000" when sel = "110" else
           "10000000";
end comb;
```

Priority Encoder



```
library ieee;
use ieee.std_logic_1164.all;
use ieee.numeric_std.all;

entity priority is
  port (
    sel  : in  std_logic_vector(7 downto 0);
    code : out unsigned(2 downto 0));
end priority;
```

```
architecture imp of priority is
begin
  code <= "000" when sel(0) = '1' else
    "001" when sel(1) = '1' else
    "010" when sel(2) = '1' else
    "011" when sel(3) = '1' else
    "100" when sel(4) = '1' else
    "101" when sel(5) = '1' else
    "110" when sel(6) = '1' else
    "111";
```

Integer Arithmetic



```
library ieee;
use ieee.std_logic_1164.all;
use ieee.numeric_std.all;

entity adder is
  port (
    A, B : in  unsigned(7 downto 0);
    CI   : in  std_logic;
    SUM  : out unsigned(7 downto 0);
    CO   : out std_logic);
end adder;

architecture imp of adder is
  signal tmp : unsigned(8 downto 0);
begin
  tmp <= A + B + ("0" & ci); -- trick to promote ci to unsigned
  SUM <= tmp(7 downto 0);
  CO  <= tmp(8);
end imp;
```

A Very Simple ALU

```
library ieee;
use ieee.std_logic_1164.all;
use ieee.numeric_std.all;

entity alu is
  port (
    A, B : in  unsigned(7 downto 0);
    ADD  : in  std_logic;
    RES  : out unsigned(7 downto 0));
end alu;

architecture imp of alu is
begin
  RES <= A + B when ADD = '1' else
        A - B;
end imp;
```

Arithmetic Comparison

```
library ieee;
use ieee.std_logic_1164.all;
use ieee.numeric_std.all;

entity comparator is
  port (
    A, B : in  unsigned(7 downto 0);
    GE   : out std_logic);
end comparator;

architecture imp of comparator is
begin
  GE <= '1' when A >= B else '0';
end imp;
```

Tri-state drivers

How to use a pin as both an input and output.

Not for internal FPGA signals.

```
library ieee;
use ieee.std_logic_1164.all;
use ieee.numeric_std.all;

entity tri_demo is
    port(addr : out unsigned(15 downto 0);    -- output only
          data : inout unsigned(7 downto 0)); -- bidirectional
end tri_demo;

architecture rtl of tri_demo is
    signal oe : std_logic; -- output enable: control direction of data
    signal d_out : unsigned(7 downto 0);
begin

    data <= d_out when oe = '1' else -- Drive data to chip
        (others => 'Z'); -- Read data from external chip

end rtl;
```

Syntax of Expressions

Logical operators: **and or xor nand nor**

Relational operators: **= /= < <= > >=**

Additive operators: **+ - &** (concatenation)

Multiplicative operators: *** / mod rem**

Others: **abs not **** (exponentiation)

Primitives: identifier

literal

name(expr to expr)

name(expr downto expr)

(choice (| choice)^{} => expr)*

Summary of Dataflow Modeling

- Conditional signal assignment (when...else)

```
target <=  
  (expr when expr else)*  
  expr ;
```

- Selected signal assignment (with...select)

```
with expr select  
  target <=  
  (expr when choice (| choice)* ,)*  
  expr when choice (| choice)* ;
```

A *choice* is a simple expression (i.e., not logical or comparison) or **others**.

Note: **when** does not nest (i.e., it's not an *expr*).



Hierarchy: Instantiating components (entities)

Hierarchy: port map positional style

```
library ieee;  
use ieee.std_logic_1164.all;  
use ieee.numeric_std.all;  
entity add2 is  
    port (A, B : in  unsigned(1 downto 0);  
          C    : out unsigned(2 downto 0));  
end add2;
```

```
architecture imp of add2 is  
  
    component full_adder  
        port (a, b, c      : in  std_logic;  
              sum, carry : out std_logic);  
    end component;
```

```
    signal carry : std_logic;
```

```
begin
```

```
    bit0 : full_adder port map ( A(0), B(0), '0', C(0), carry );
```

```
    bit1 : full_adder port map ( A(1), B(1), carry, C(1), C(2) );
```

```
end imp;
```

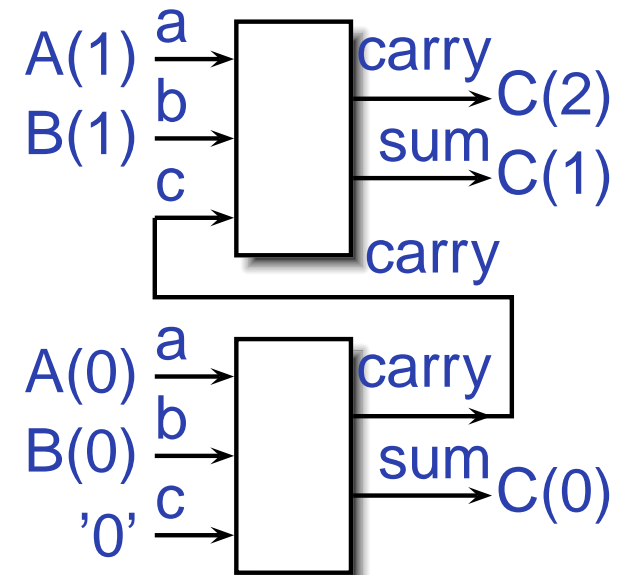

Hierarchy: port map by-name style

```
library ieee;
use ieee.std_logic_1164.all;
use ieee.numeric_std.all;
entity add2n is
    port (A, B : in  unsigned(1 downto 0);
          C    : out unsigned(2 downto 0));
end add2n;
architecture imp of add2n is
    component full_adder
        port (a, b, c    : in  std_logic;
              sum, carry : out std_logic);
    end component;
    signal carry : std_logic;
begin
    bit0 : full_adder port map (a => A(0), b => B(0), c => '0',
                               sum => C(0), carry => carry);

    bit1 : full_adder port map (a => A(1), b => B(1), c => carry,
                               sum => C(1), carry => C(2));
end imp;
```

Direct Instantiation (no component)

```
library ieee;
use ieee.std_logic_1164.all;
use ieee.numeric_std.all;

entity add2 is
    port (A, B : in  unsigned(1 downto 0);
          C    : out unsigned(2 downto 0));
end add2;

architecture imp of add2 is
    signal carry : std_logic;
begin
    bit0 : entity work.full_adder -- everything in "work" project
        port map ( A(0), B(0), '0', C(0), carry );

    bit1 : entity work.full_adder
        port map ( A(1), B(1), carry, C(1), C(2) );
end imp;
```

Must be compiled after full_adder.vhd!

Generate: Ripple-carry adder

```
library ieee;
use ieee.std_logic_1164.all;
use ieee.numeric_std.all;
entity rippleadder is
    port (a, b : in unsigned(3 downto 0);
          cin : in std_logic;
          sum : out unsigned(3 downto 0);
          cout : out std_logic);
end rippleadder;

architecture imp of rippleadder is
    signal c : unsigned(4 downto 0);
begin
    c(0) <= cin;
    G1: for m in 0 to 3 generate -- expanded at compile time
        sum(m) <= a(m) xor b(m) xor c(m);
        c(m+1) <= (a(m) and b(m)) or (b(m) and c(m)) or
                 (a(m) and c(m));
    end generate G1;
    cout <= c(4);
end imp;
```



Combinational Logic in a Procedural Style

Processes

Process: sequential code fragment invoked when signal in sensitivity list changes.

A correct, but dumb way to model an inverter:

```
library ieee;
use ieee.std_logic_1164.all;

entity dumb_inv is
  port( a: in std_logic; y : out std_logic );
end dumb_inv;

architecture comb of dumb_inv is
begin
  process (a) -- invoked when signal a changes
  begin
    if a = '1' then y <= '0'; else y <= '1'; end if;
  end process;
end comb;
```

A 4-to-1 mux in the procedural style

```
library ieee;
use ieee.std_logic_1164.all;
use ieee.numeric_std.all;
entity pmultiplexer_4_1 is
    port(in0, in1, in2, in3 : in  unsigned(15 downto 0);
          s                   : in  unsigned(1 downto 0);
          z                   : out unsigned(15 downto 0));
end pmultiplexer_4_1;

architecture comb of pmultiplexer_4_1 is
begin
    process (in0, in1, in2, in3, s)
    begin
        z <= (others => 'X'); -- default
        if    s = "00" then z <= in0; -- assignment overrides default
        elsif s = "01" then z <= in1;
        elsif s = "10" then z <= in2;
        elsif s = "11" then z <= in3;
        end if;
    end process;
end architecture;
```

A 4-to-1 mux using case

```
library ieee;
use ieee.std_logic_1164.all;
use ieee.numeric_std.all;
entity cmultiplexer_4_1 is
    port(in0, in1, in2, in3 : in  unsigned(15 downto 0);
          s                   : in  unsigned(1 downto 0);
          z                   : out unsigned(15 downto 0));
end cmultiplexer_4_1;
architecture comb of cmultiplexer_4_1 is
begin
    process (in0, in1, in2, in3, s)
    begin
        case s is
            when "00"    => z <= in0;
            when "01"    => z <= in1;
            when "10"    => z <= in2;
            when "11"    => z <= in3;
            when others => z <= (others => 'X');
        end case;
    end process;
end architecture;
```

An Address Decoder

```
library ieee;
use ieee.std_logic_1164.all;
use ieee.numeric_std.all;
entity adecoder is
    port(a : in unsigned(15 downto 0);
         ram, rom, video, io : out std_logic);
end adecoder;

architecture proc of adecoder is
begin
    process (a)
    begin
        ram <= '0'; rom <= '0'; video <= '0'; io <= '0';
        if a(15) = '0' then ram <= '1';           -- 0000-7FFF
        elsif a(14 downto 13) = "00" then video <= '1'; -- 8000-9FFF
        elsif a(14 downto 12) = "101" then io <= '1'; -- D000-DFFF
        elsif a(14 downto 13) = "11" then rom <= '1'; -- E000-FFFF
        end if;
    end process;
end proc;
```

Summary of Procedural Modeling

- **null**
- *signal* <= *expr* ;
- *variable* := *expr* ;
- **if** *expr* **then** *stmts*
(**elsif** *expr* **then** *stmts*)*
(**else** *stmts*)?
end if;
- **case** *expr* **is**
(**when** *choices* => *stmts*)*
end case;

Note: **when...else** and **with...select** *not* allowed



Sequential Logic

Basic D Flip-Flop



```
library ieee;
use ieee.std_logic_1164.all;

entity flipflop is
    port (Clk, D : in  std_logic;
          Q      : out std_logic);
end flipflop;
```

```
architecture imp of flipflop is
begin
```

```
    process (Clk)    -- Sensitive only to Clk
    begin
        if rising_edge(Clk) then -- Only on the rising edge of Clk
            Q <= D;
        end if;
    end process;
```

```
end imp;
```

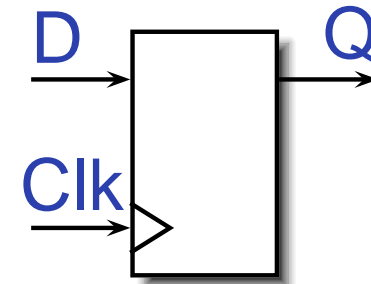

Flip-Flop with Latch Enable

```
library ieee;  
use ieee.std_logic_1164.all;  
entity flipflop_enable is  
    port (Clk, Reset, D, EN : in  std_logic;  
          Q                   : out std_logic);  
end flipflop_enable;
```

```
architecture imp of flipflop_enable is  
begin
```

```
    process (Clk)  
    begin  
        if rising_edge(Clk) then  
            if EN = '1' then  
                Q <= D;  
            end if;  
        end if;  
    end process;  
end imp;
```

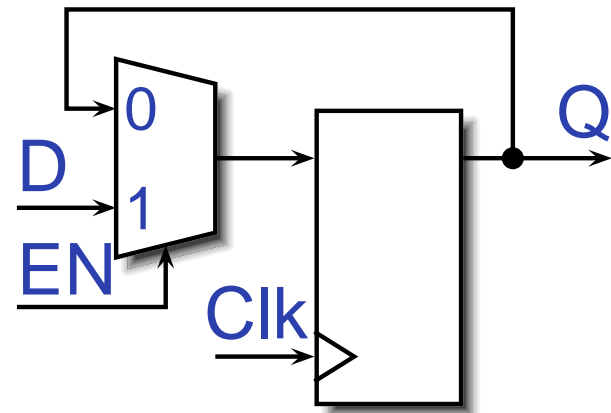

Flip-Flop with Synchronous Reset

```
library ieee;
use ieee.std_logic_1164.all;
entity flipflop_reset is
    port (Clk, Reset, D : in std_logic;
          Q           : out std_logic);
end flipflop_reset;
```

```
architecture imp of flipflop_reset is
begin
    process (Clk)
    begin
        if rising_edge(Clk) then
            if Reset = '1' then
                Q <= '0';
            else
                Q <= D;
            end if;
        end if;
    end process;
end imp;
```

Four-bit binary counter



```
library ieee;
use ieee.std_logic_1164.all;
use ieee.numeric_std.all;
entity counter is
    port(Clk, Reset : in std_logic;
         Q          : out unsigned(3 downto 0));
end counter;
architecture imp of counter is
    signal count : unsigned(3 downto 0);
begin
    process (Clk)
    begin
        if rising_edge(Clk) then
            if Reset = '1' then count <= (others => '0');
            else count <= count + 1;
            end if;
        end if;
    end process;
    Q <= count;    -- copy count to output
end imp;
```

Eight-bit serial in/out shift register

```
library ieee;
use ieee.std_logic_1164.all;

entity shifter is
    port ( Clk, SI : in  std_logic;
          SO  : out std_logic);
end shifter;

architecture impl of shifter is
    signal tmp : std_logic_vector(7 downto 0);
begin
    process (Clk)
    begin
        if rising_edge(Clk) then
            tmp <= tmp(6 downto 0) & SI; -- & is concatenation
        end if;
    end process;

    SO <= tmp(7); -- Copy to output
end impl;
```

Synchronous RAM



```
library ieee;
use ieee.std_logic_1164.all;
use ieee.numeric_std.all;
entity ram_32_4 is
  port (
    Clk, WE : in std_logic; -- Clock and write enable
    addr    : in unsigned(4 downto 0);
    di      : in unsigned(3 downto 0); -- Data in
    do      : out unsigned(3 downto 0)); -- Data out
end ram_32_4;
architecture imp of ram_32_4 is
  type ram_type is array(0 to 31) of unsigned(3 downto 0);
  signal RAM : ram_type;
begin
  process (Clk) begin
    if rising_edge(Clk) then
      if we = '1' then RAM(TO_INTEGER(addr)) <= di;
        do <= di; -- write-through
      else do <= RAM(TO_INTEGER(addr));
    end if; end if;
  end process;
```

A small ROM

```
library ieee;
use ieee.std_logic_1164.all;
use ieee.numeric_std.all;
entity rom_32_4 is
    port (Clk, en : in std_logic;
          addr   : in unsigned(3 downto 0);
          data   : out unsigned(3 downto 0));
end rom_32_4;
architecture imp of rom_32_4 is
type rom_type is array (0 to 15) of unsigned(3 downto 0);
constant ROM : rom_type :=
    (X"1", X"2", X"3", X"4", X"5", X"6", X"7", X"8",
     X"9", X"A", X"B", X"C", X"D", X"E", X"F", X"1");
begin
process (Clk)
begin
    if rising_edge(Clk) then
        if en = '1' then data <= ROM(TO_INTEGER(addr)); end if;
    end if;
end process;
end imp;
```

Variables and Signals

```
library ieee; use ieee.std_logic_1164.all;
entity twoshiftreg is
  port(clk, si1, si2 : in std_logic; so1, so2 : out std_logic);
end twoshiftreg;
architecture imp of twoshiftreg is
  signal sr1 : std_logic_vector(1 downto 0); -- visible globally
begin
  process (clk)
    variable sr2 : std_logic_vector(1 downto 0); -- process-only
  begin
    if rising_edge(clk) then
      sr1(1) <= si1;      -- Effect seen only after next clk
      sr1(0) <= sr1(1); -- Any order works
      so1 <= sr1(0);

      so2 <= sr2(0);
      sr2(0) := sr2(1); -- Effect seen immediately
      sr2(1) := si2;    -- Must be in this order
    end if;
  end process;
end imp;
```

Variables vs. Signals

Property	Variables	Signals
Scope	Local to process	Visible throughout architecture
Assignment	Felt immediately (e.g., in next statement)	Only visible after clock rises (i.e., process terminates)

Lesson: use variables to hold temporary results and state to be hidden within a process. Otherwise, use signals.

Constants: A VGA sync generator

```
library ieee; use ieee.std_logic_1164.all; use ieee.numeric_std.all;
entity sync_gen is
    port (clk : in std_logic; hs, vs : out std_logic);
end sync_gen;

architecture rtl of sync_gen is
    constant HTOTAL : integer := 800; constant HSYNC : integer := 96;
    constant VTOTAL : integer := 525; constant VSYNC : integer := 2;
    signal hcount, vcount : unsigned(9 downto 0);
begin
    process (clk)
    begin
        if rising_edge(clk) then
            if hcount = HTOTAL - 1 then
                hcount <= (others => '0'); hs <= '1';
                if vcount = VTOTAL - 1 then
                    vcount <= (others => '0'); vs <= '1';
                else
                    if vcount = VSYNC then vs <= '0'; end if;
                    vcount <= vcount + 1;
                end if;
            else
                if hcount = HSYNC then hs <= '0'; end if;
                hcount <= hcount + 1;
            end if;
        end if;
    end process;
end sync_gen;
```

Rocket Science: FSMs

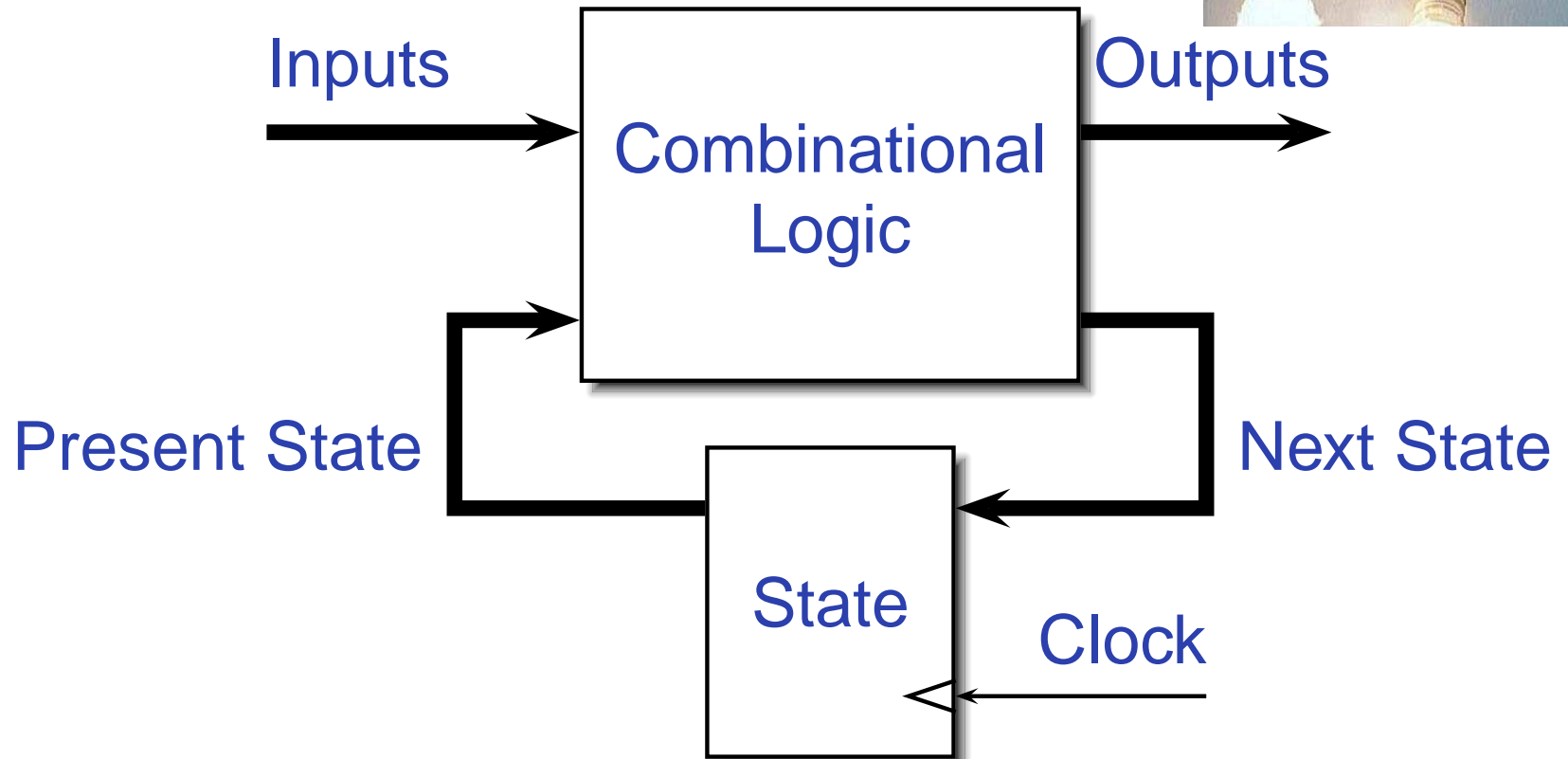
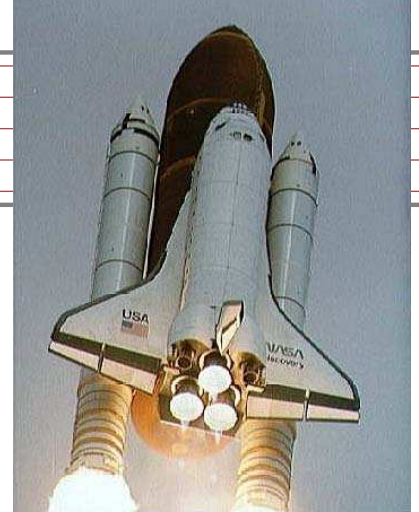

This is a *Mealy* FSM: outputs may depend directly on inputs.

Moore FSMs

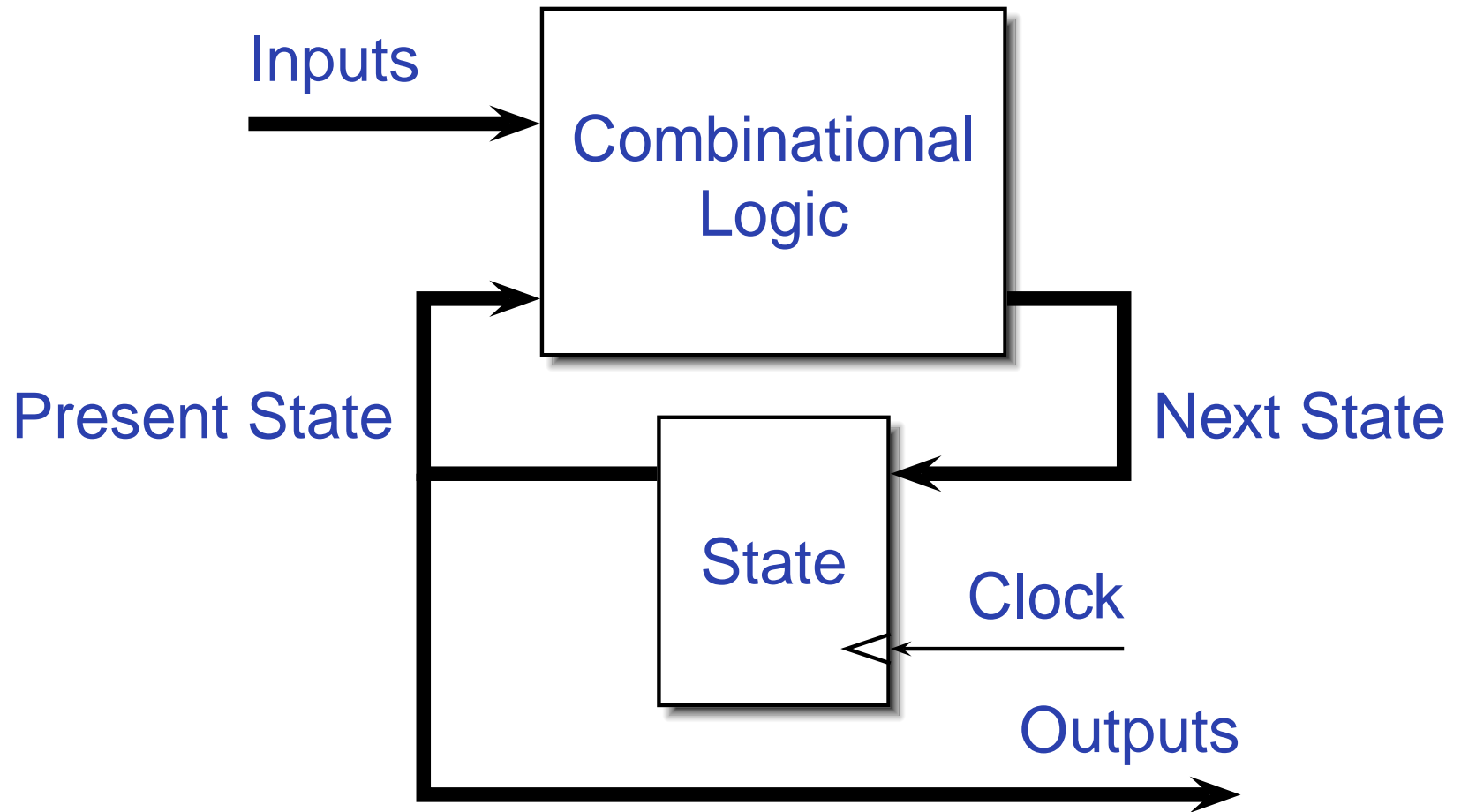

This is a *Moore* FSM: outputs come from state bits.

Coding Moore State Machines

```
library ieee; use ieee.std_logic_1164.all;
entity threecount is
    port(clk, reset, count : in std_logic; at0 : out std_logic);
end threecount;
architecture moore of threecount is
    type states is (ZERO, ONE, TWO); -- States encoded automatically
begin
    process (clk)
        variable state : states;
    begin
        if rising_edge(clk) then
            if reset = '1' then state := ZERO;
            else case state is
                when ZERO => if count = '1' then state := ONE; end if;
                when ONE  => if count = '1' then state := TWO; end if;
                when TWO  => if count = '1' then state := ZERO; end if;
            end case;
        end if;
        if state = ZERO then at0 <= '1'; else at0 <= '0'; end if;
    end if;
end process; end moore;
```

Coding Mealy State Machines

```
architecture mealy of ... is
type states is (IDLE, STATE1, ...);
signal state, next_state : states;
begin
process (clk) -- Sequential process
begin
    if rising_edge(clk) then state <= next_state; end if;
end process;

process (reset, state, i1, i2, ... ) -- Combinational process
begin
    next_state <= state; -- Default: hold
    if reset = '1' then
        next_state <= IDLE;
    else
        case state is
        when IDLE =>
            if i1 = '1' then
                next_state <= STATE1;
            end if;
        when STATE1 =>
```

The Traffic Light Controller

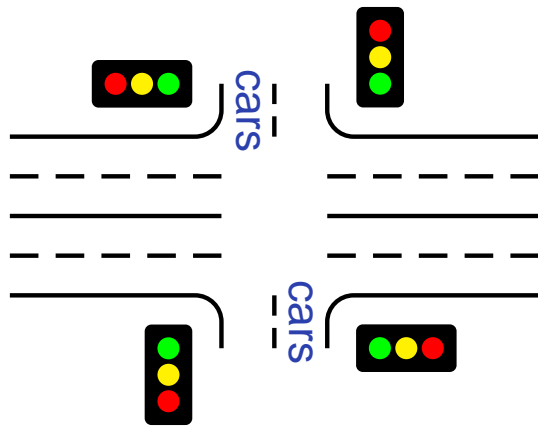

This controls a traffic light at the intersection of a busy highway and a farm road. Normally, the highway light is green but if a sensor detects a car on the farm road, the highway light turns yellow then red. The farm road light then turns green until there are no cars or after a long timeout. Then, the farm road light turns yellow then red, and the highway light returns to green. The inputs to the machine are the car sensor, a short timeout signal, and a long timeout signal. The outputs are a timer start signal and the colors of the highway and farm road lights.

Source: Mead and Conway, *Introduction to VLSI Systems*, 1980, p. 85.

FSM for the Traffic Light Controller

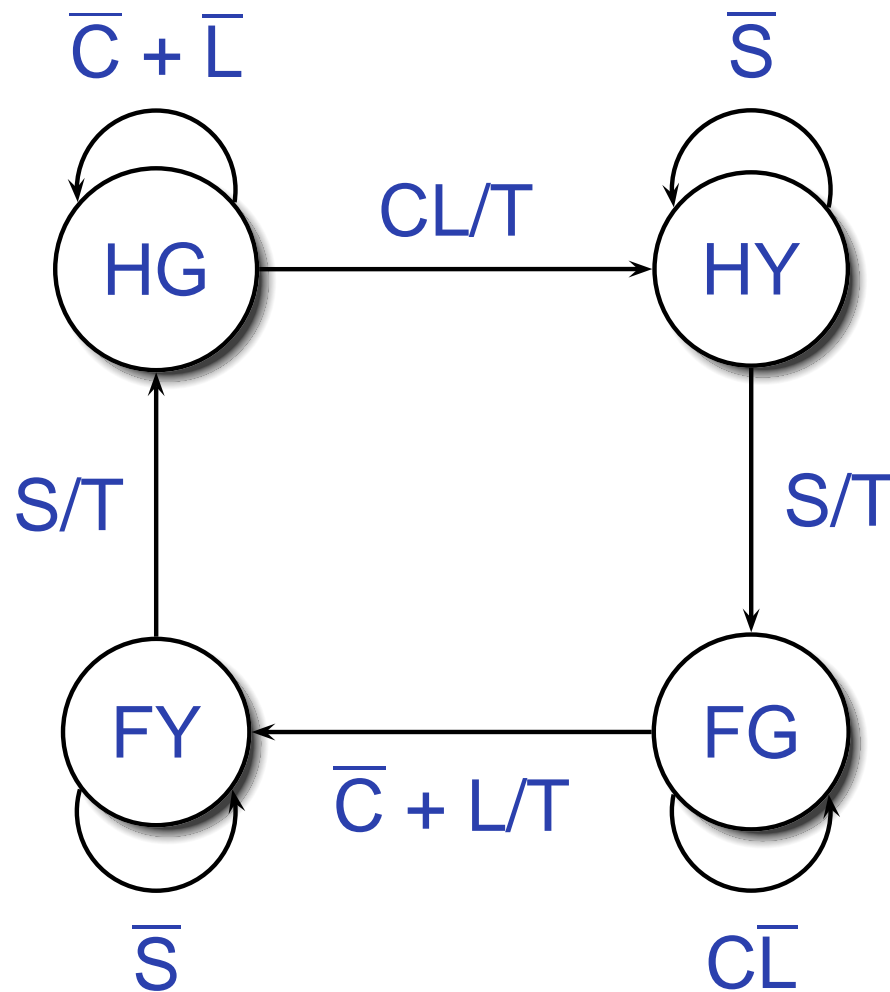

C: Car sensor
 S: Short timeout
 L: Long timeout
 T: Start timer

St	Hwy	Farm
HG	G	R
HY	Y	R
FG	R	G
FY	R	Y

Traffic Light Controller in VHDL

```
library ieee;
use ieee.std_logic_1164.all;
entity tlc is
    port (clk, reset           : in  std_logic;
          cars, short, long    : in  std_logic;
          highway_yellow, highway_red : out std_logic;
          farm_yellow, farm_red   : out std_logic;
          start_timer          : out std_logic);
end tlc;

architecture imp of tlc is
type states is (HG, HY, FY, FG);
signal state, next_state : states;
begin
    process (clk)      -- Sequential process
    begin
        if rising_edge(clk) then
            state <= next_state;
        end if;
    end process;
end architecture;
```

TLC in VHDL, continued

```
process (state, reset, cars, short, long)
begin
  if reset = '1' then
    start_timer <= '1'; next_state <= HG;
  else
    case state is
      when HG =>
        highway_yellow <= '0'; highway_red <= '0';
        farm_yellow <= '0'; farm_red <= '1';
        if cars = '1' and long = '1' then
          start_timer <= '1'; next_state <= HY;
        else start_timer <= '0'; next_state <= HG;
        end if;
      when HY =>
        highway_yellow <= '1'; highway_red <= '0';
        farm_yellow <= '0'; farm_red <= '1';
        if short = '1' then
          start_timer <= '1'; next_state <= FG;
        else start_timer <= '0'; next_state <= HY;
        end if;
    end case;
  end if;
end process;
```

TLC in VHDL, concluded

```
when FG =>
    highway_yellow <= '0'; highway_red    <= '1';
    farm_yellow    <= '0'; farm_red      <= '0';
    if cars = '0' or long = '1' then
        start_timer <= '1'; next_state <= FY;
    else start_timer <= '0'; next_state <= FG;
    end if;
when FY =>
    highway_yellow <= '0'; highway_red    <= '1';
    farm_yellow    <= '1'; farm_red      <= '0';
    if short = '1' then
        start_timer <= '1'; next_state <= HG;
    else start_timer <= '0'; next_state <= FY;
    end if;
end case;
end if;
end process;

end imp;
```



Summary of the Three Modeling Styles

Three Modeling Styles: Dataflow (1)

Combinational logic described by expressions

-- Simple case

```
a <= x and y;
```

-- When...else selector

```
b <= '1' when x = y else  
    '0';
```

--- With..select selector

```
with x select
```

```
c <=  
    '1' when '0',  
    '0' when '1',  
    'X' when others;
```

Procedural Combinational (2)

Combinational logic described by statements and expressions

```
process (x, y) -- Should be sensitive to every signal it reads
begin
    a <= x and y;
    if x = y then
        b <= '1';
    else
        b <= '0';
    end if;
    case x of
        '0' => c <= '1';
        '1' => c <= '0';
        others => c <= 'X';
    end case;
end process;
```

Three Styles: Procedural Sequential

Combinational logic driving flip-flops described by statements and expressions.

```
process (clk) -- Sensitive only to the clock
begin
    if rising_edge(clk) then -- Always check for rising edge
        a <= x and y;
        if x = y then
            b <= '1';
        else
            b <= '0';
        end if;
        case x of
            '0' => c <= '1';
            '1' => c <= '0';
            others => c <= 'X';
        end case;
    end if;
end process;
```

Ten Commandments of VHDL

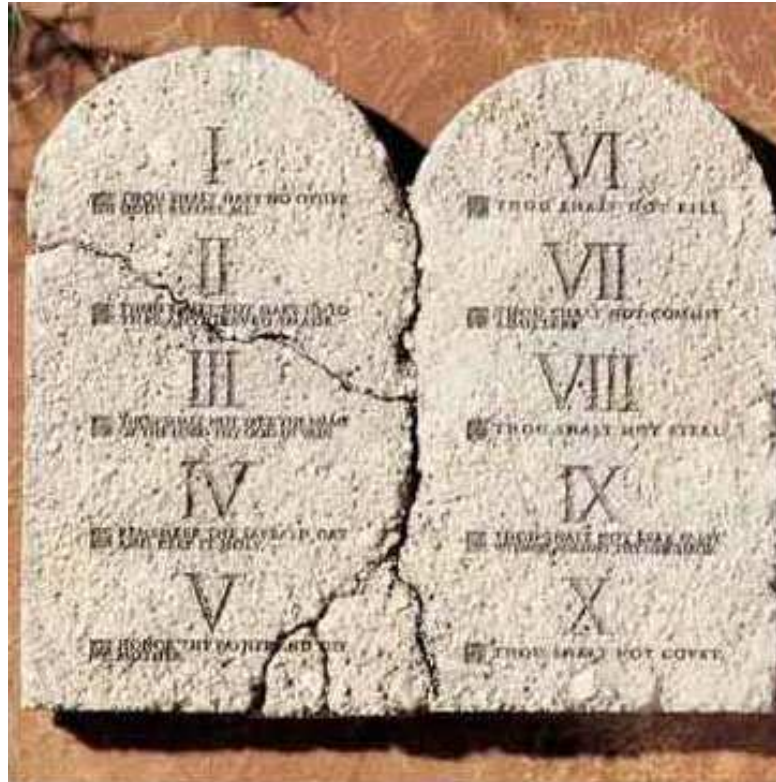

I: Thou Shalt Design Before Coding

- Know the structure of what you are designing first.
- Draw a block diagram of the datapath
- Understand the timing (draw diagrams)
- Draw bubble-and-arc diagrams for FSMs
- Only once you have a design should you start coding in VHDL
- VHDL is only a way to ask for component

Block Diagram of a Character Gen.

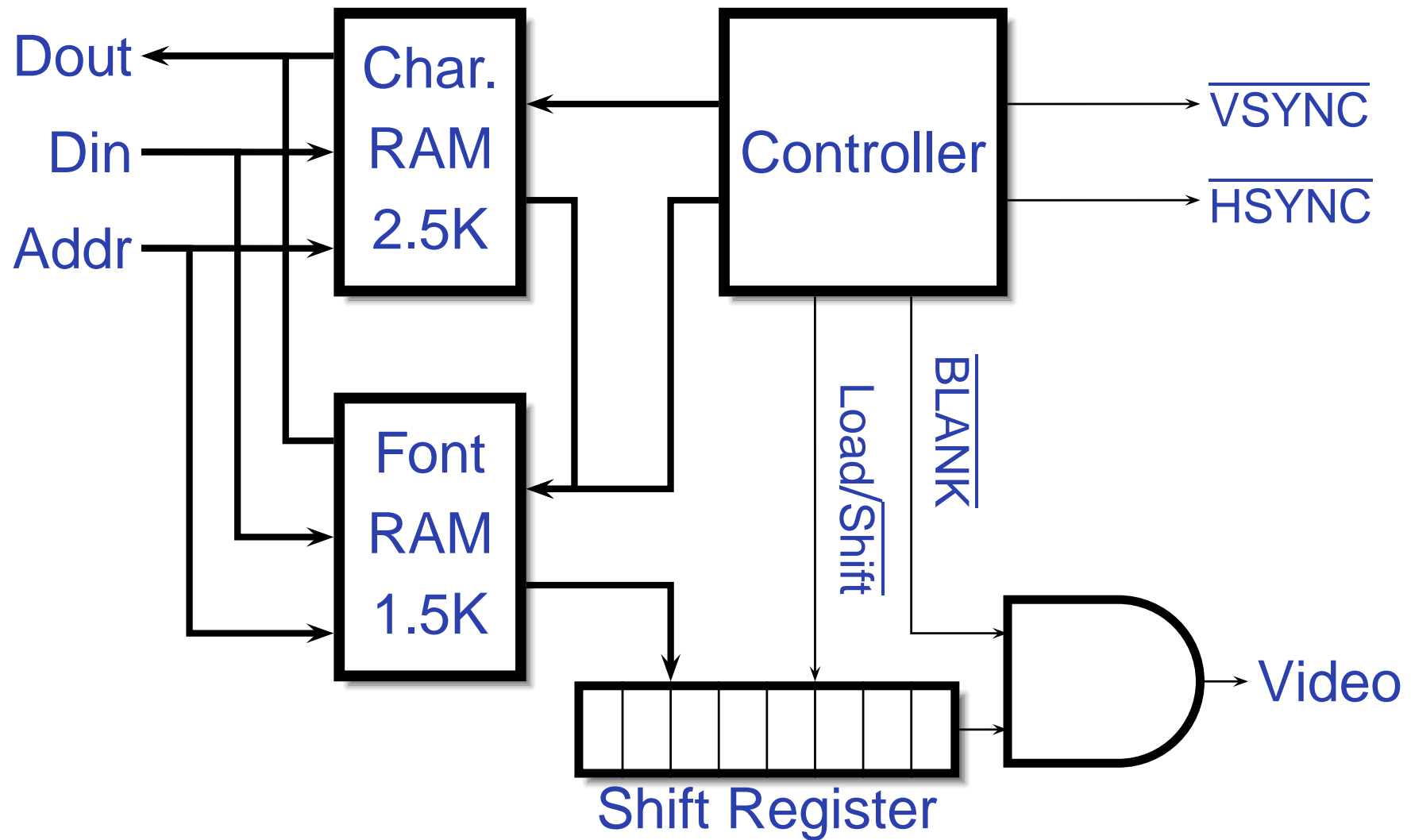

Pixel-Level Timing

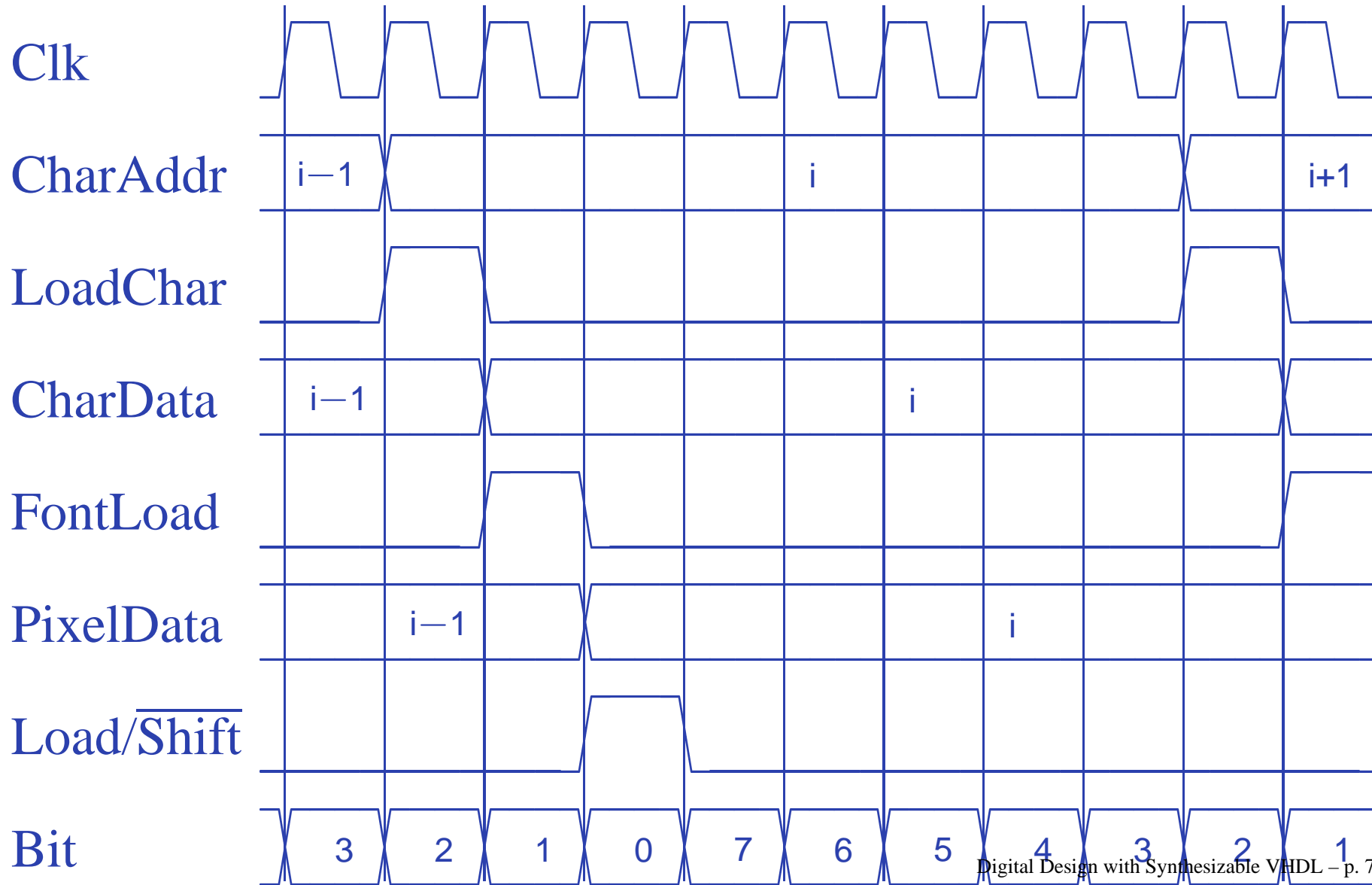

Start-of-line Detail

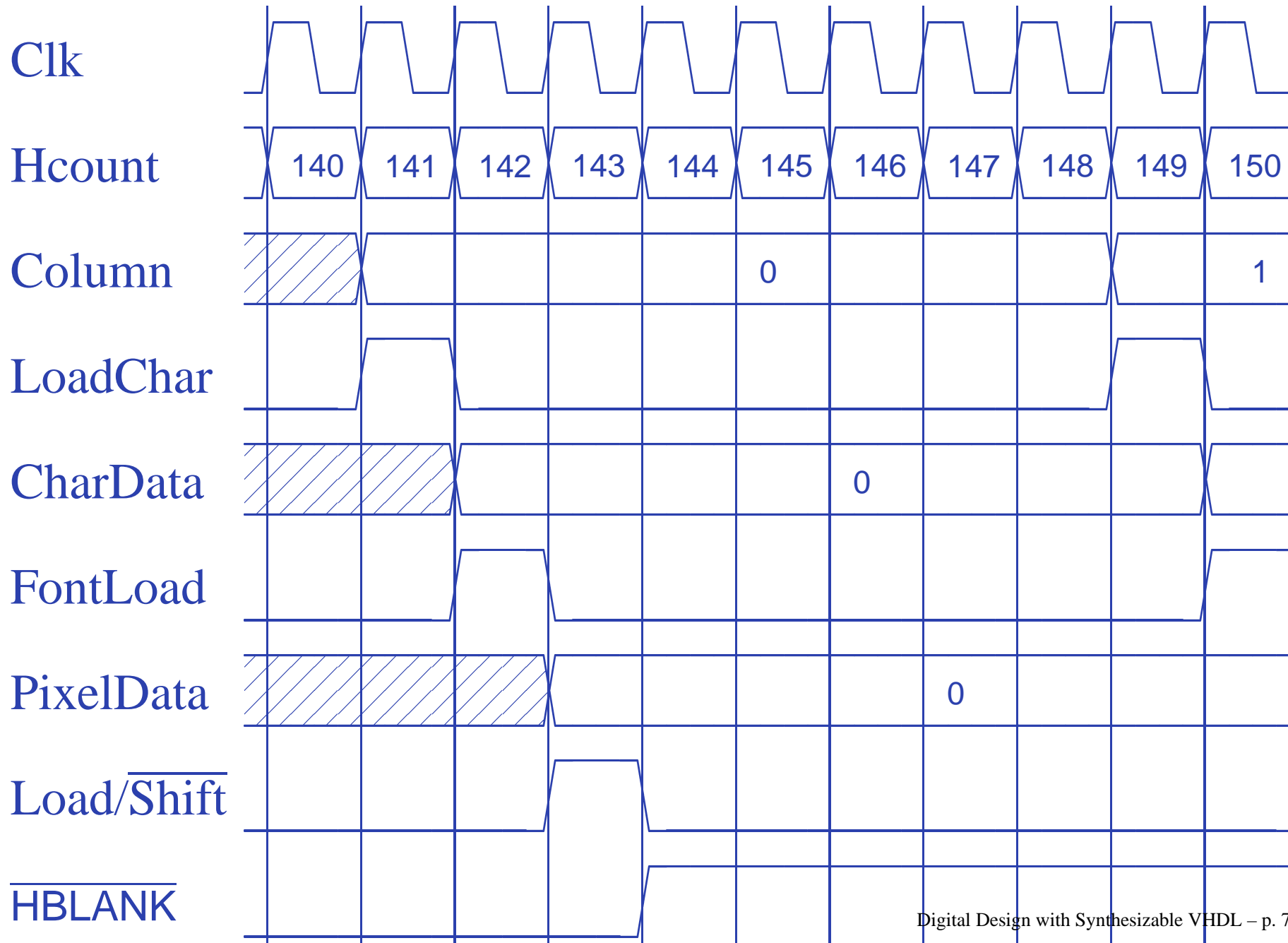

End-of-line detail

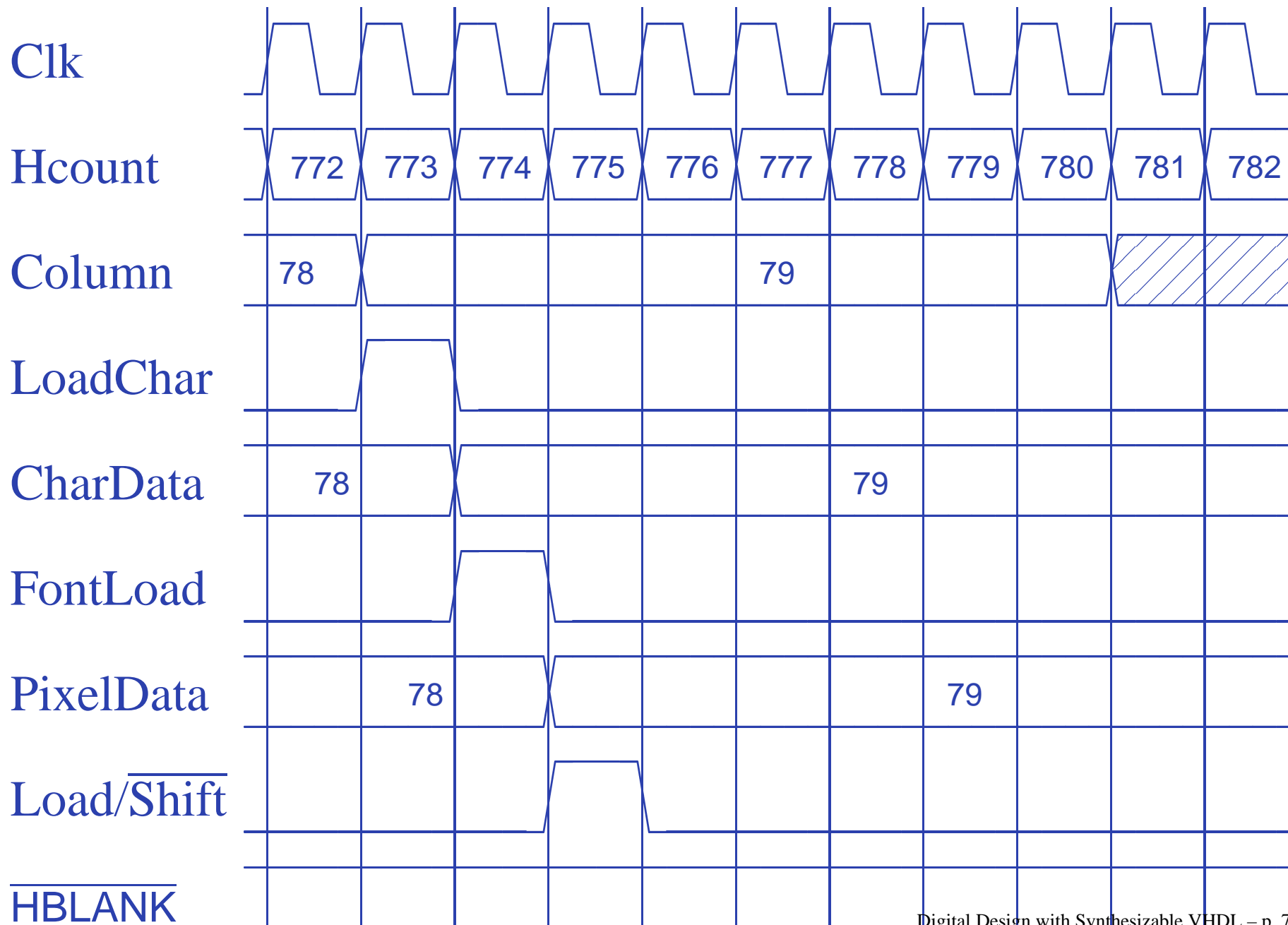

II: Thou Shalt be Synchronous

- One global clock
- Flip-flops generate inputs to combinational logic, which computes inputs to flip-flops
- Exactly one value per signal per clock cycle
- Do not generate asynchronous reset signals; only use them if they are external
- Edge-triggered flip-flops only. Do not use level-sensitive logic.
- Do not generate clock signals. Use multiplexers to create “load enable” signals on flip-flops.

III: Thou Shalt Be Sensitive

Combinational processes: list all process inputs

```
process (state, long)
begin
  if reset = '1' then
    next_state <= HG;
    start_timer <= '1';
  else
    case state is
      when HG =>
        farm_yellow <= '0';
        if cars = '1' and long = '1' then
          next_state <= HY;
        else
          next_state <= HG;
        end if;
      when HY =>
        farm_yellow <= '0';
        if short = '1' then
          next_state <= FG;
        else
          next_state <= HY;
        end if;
    end case;
  end if;
end process;
```

```
process (state, reset, cars, short, long)
begin
  if reset = '1' then
    next_state <= HG;
    start_timer <= '1';
  else
    case state is
      when HG =>
        farm_yellow <= '0';
        if cars = '1' and long = '1' then
          next_state <= HY;
        else
          next_state <= HG;
        end if;
      when HY =>
        farm_yellow <= '0';
        if short = '1' then
          next_state <= FG;
        else
          next_state <= HY;
        end if;
    end case;
  end if;
end process;
```

III: Thou Shalt Be Sensitive

Sequential processes: always include the clock.
Include reset if asynchronous, and nothing else.

```
process (Clk, D)
begin
  if rising_edge(Clk) then
    Q <= D;
  end if;
end process;
```

```
process (Clk, D)
begin
  if reset = '1' then
    Q <= '0';
  else
    if rising_edge(Clk) then
      Q <= D;
    end if;
  end if;
end process;
```

```
process (Clk)
begin
  if rising_edge(Clk) then
    Q <= D;
  end if;
end process;
```

```
process (Clk, reset)
begin
  if reset = '1' then
    Q <= '0';
  else
    if rising_edge(Clk) then
      Q <= D;
    end if;
  end if;
end process;
```

IV: Thou Shalt Assign All Outputs

Synthesis infers level-sensitive latches if sometimes you do not assign an output.

```
process (state, input)
begin
  case state is
    when S1 =>
      if input = '1' then
        output <= '0';
      end if;
    when S2 =>
      output <= '1';
    end case;
end process;
```

```
process (state, input)
begin
  case state is
    when S1 =>
      if input = '1' then
        output <= '0';
      else
        output <= '1';
      end if;
    when S2 =>
      output <= '1';
    end case;
end process;
```

“Default” values are convenient

-- OK

```
process (state, input)
begin
  case state is
    when S1 =>
      if input = '1' then
        output <= '0';
      else
        output <= '1';
      end if;
    when S2 =>
      output <= '1';
  end case;
end process;
```

-- Better

```
process (state, input)
begin
  output <= '1';
  case state is
    when S1 =>
      if input = '1' then
        output <= '0';
      end if;
  end case;
end process;
```

V: Thou Shalt Enumerate States

Better to use an enumeration to encode states:

```
type states is (START, RUN, IDLE, ZAPHOD);  
signal current, next : states;
```

```
process (current)  
begin  
  case current is  
    when START => ...  
    when RUN => ...  
    when IDLE => ...  
  end case;  
end process;
```

Running this produces a helpful error:

```
Compiling vhd1 file "/home/cristi/cs4840/lab4/main.vhd" in Library work.  
Entity <system> compiled.  
ERROR:HDLParasers:813 - "/home/cristi/cs4840/lab4/main.vhd" Line 80.  
Enumerated value zaphod is missing in case.  
-->
```

VI:



(There is no rule six)

VII: Thou Shalt Avoid Async

Only use asynchronous reset when there is one global signal from outside.

-- OK for external Reset

```
process (Clk, Reset)
begin
  if Reset = '1' then
    Q <= '0';
  else
    if rising_edge(Clk) then
      Q <= D;
    end if;
  end if;
end process;
```

-- Better

```
process (Clk)
begin
  if rising_edge(Clk) then
    if Reset = '1' then
      Q <= '0';
    else
      Q <= D;
    end if;
  end if;
end process;
```

Never generate your own asynchronous reset.
Generating a synchronous reset is fine

VIII: Thou Shalt Have One Version

- Never assume signals from the test bench that are not there on the board
- It is hard enough to make simulation match the design; do not make it any harder
- If you must slow down hardware, carefully generate a slower clock and only use that clock globally.

IX: Thou Shalt Not Test For X Or Z

```
architecture behv of ALU is begin
  process (A,B,Sel) begin
    case Sel is
      when "00" => Res <= A + B;
      when "01" => Res <= A + (not B) + 1;
      when "1X" => Res <= A and B;
      when "1Z" => Res <= A or B;
      when others => Res <= "XX";
    end case;
  end process;
end behv;
```

```
architecture behv of ALU is begin
  process(A,B,Sel) begin
    case Sel is
      when "00" => Res <= A + B;
      when "01" => Res <= A + (not B) + 1;
      when "10" => Res <= A and B;
      when "11" => Res <= A or B;
      when others => Res <= "XX";
    end case;
  end process;
end behv;
```

This is legal VHDL, but the synthesized circuit won't behave like you expect.

X: Thou Shalt Not Specify Delays

- The `wait` statement can delay for a certain amount of time, e.g., “`wait 10ns;`”
- Only use it in test benches that are not meant to become hardware
- Do not use them in the design of your hardware

Pitfalls: Boolean vs. Std_logic

Don't assign Boolean to std_logic.

```
signal a : std_logic;  
signal b : unsigned(7 downto 0);
```

```
a <= b = x"7E"; -- BAD: result is Boolean, not std_logic
```

```
a <= '1' when b = x"7E" else '0'; -- OK
```

Don't test std_logic in a Boolean context.

```
signal a, b, foo : std_logic;
```

```
if a then -- BAD: A is not Boolean
```

```
    foo <= '1';
```

```
end if;
```

```
b <= '0' when a else '1'; -- BAD: a is not Boolean
```

```
if a = '1' then -- OK
```

```
    foo <= '1';
```

Pitfalls: Inferring a Latch

In a combinational process, make sure all output signals are always assigned.

```
process (x, y)
begin
  if x = '1' then
    y <= '0';
  end if;
  -- BAD: y not assigned when x = '0', synthesis infers a latch
end process;
```

```
process (x, y)
begin
  y <= '1'; -- OK: y is always assigned
  if x = '1' then
    y <= '0';
  end if;
end process
```

Pitfalls: Reading Output Port

```
library ieee;
use ieee.std_logic_1164.all;
entity dont_read_output is
  port ( a : in std_logic;
         x, y : out std_logic );
end dont_read_output;
```

```
architecture BAD of dont_read_output is
begin
  x <= not a;
  y <= not x; -- Error: can't read an output port
end BAD;
```

```
architecture OK of dont_read_output is
signal x_sig : std_logic;
begin
  x_sig <= not a;
  x <= x_sig; -- x_sig just another name for x
  y <= not x_sig; -- OK
end OK;
```

Pitfalls: Complex Port Map Args

```
library ieee;
use ieee.std_logic_1164.all;
use ieee.numeric_std.all;
entity bad_port_map is end bad_port_map;
```

```
architecture BAD of bad_port_map is
component bar port (x : in unsigned(5 downto 0) ); end component;
signal a : unsigned(3 downto 0);
begin
    mybar : bar port map ( x => "000" & a); -- BAD
end BAD;
```

```
architecture OK of bad_port_map is
component bar port (x : in unsigned(5 downto 0) ); end component;
signal a : unsigned(3 downto 0);
signal aa : unsigned(5 downto 0);
begin
    aa <= "000" & a;
    mybar : bar port map ( x => aa ); -- OK
end OK;
```

Pitfalls: Combinational Loops

You never really need them.

Drive every signal from exactly one process or concurrent assignment.

Don't build SR latches. Use D flip-flops instead.

Pitfalls: Clock Gating

Dangerous, difficult to get right.

Use a single, global clock and latch enables to perform the same function.

Pitfalls: Multiple Clock Domains

If you must, vary the phase and drive clocks directly from flip-flops.



Writing Testbenches

Testbenches

One of VHDL's key points: can describe hardware and environment together.

```
-- Explicit delays are allowed  
clk <= not clk after 50 ns;
```

```
process  
begin
```

```
    reset <= '0';  
    wait 10 ns;           -- Explicit delay  
    reset <= '1';  
    wait for a = '1'; -- Delay for an event  
    assert b = '1' report "b_did_not_rise" severity failure;  
    assert c = '1' report "c=0" severity warning; -- or error or note  
    wait for 50 ns;      -- Delay for some time  
    wait;                -- Halt this process  
end process;
```

Testbench Methodology

- Always put testbench in a separate .vhd file since it cannot be synthesized.
- Instantiate block under test and apply desired inputs (clocks, other stimulus)
- Use `assert` to check conditions
- Try to emulate hardware environment as closely as possible (no special inputs, etc.)

A Testbench

```
library ieee;
use ieee.std_logic_1164.all;
use ieee.numeric_std.all;

entity tlc_tb is -- A testbench usually has no ports
end tlc_tb;

architecture tb of tlc_tb is
    signal clk : std_logic := '0'; -- Must initialize!

    -- One signal per port is typical
    signal reset, cars, short, long : std_logic;
    signal farm_red, start_timer : std_logic;
begin

    clk <= not clk after 34.92 ns; -- 14 MHz
```

A testbench continued

-- Apply stimulus and check the results

process

begin

```
cars <= '0'; short <= '0'; long <= '0'; reset <= '1';
```

```
wait for 100 ns;
```

```
assert start_timer = '1' report "No_timer" severity error;
```

```
reset <= '0';
```

```
wait for 100 ns;
```

```
assert farm_red = '1' report "Farm_not_red" severity error;
```

```
wait;
```

end process;

-- Instantiate the Unit Under Test

```
 uut : entity work.tlc
```

```
 port map ( clk => clk,      reset => reset,
```

```
           cars => cars,    short => short,
```

```
           long => long,    farm_red => farm_red,
```

```
           start_timer => start_timer);
```

end th;